



SHAVING CABINET

INSTALLATION INSTRUCTIONS

CARE & MAINTENANCE, WARRANTY

✓ PRIOR TO INSTALLATION CHECKLIST

1 Check Products For Any Damages

Within 48 hours of receiving your goods, unpack your ADP product and check for any possible freight damages or incorrect items. Please contact your place of purchase to report damages or missing parts.

No claims for damages will be recognised after installation.

2 Positioning & Ventilation

Furniture must be at least 300mm away from any wet areas. Materials used in the construction of our furniture units are moisture resistant, not water proof. Do not expose furniture to shower spray. It is important that your bathroom is adequately ventilated to eliminate moisture build up. High humidity will lead to permanent dampness and mould resulting in a deterioration of the materials in your bathroom. **Water damage is not covered under ADP Warranty.**

3 Check for Support Beams

Wall hung furniture require fixing to a support beam fitted between the studs to give a solid wall backing to attach the cabinet to.

4 Check for Plumb Walls

Ensure the wall is plumb and straight. If you fix the product to a non-plumb wall, the doors will not operate correctly and they will not align.



ARE YOU INSTALLING THIS PRODUCT?

Please read the installation instructions BEFORE INSTALLATION.

If the product is not installed in accordance with these instructions, your ADP warranty may be void and the homeowner may have a claim against you (the installer).

This product must be installed by a qualified tradesperson.



IMPORTANT - It is the responsibility of the installer to make any adjustments to doors/drawers after installation if required.

There may have been some movement in transportation and installation which causes doors/drawers to become unaligned.

PLEASE RETURN TO HOME OWNER - IMPORTANT CARE & WARRANTY INFORMATION INSIDE.

For more information visit www.adpaustralia.com.au.

SHAVING CABINET INSTALLATION

Note: If you are installing a light or powerpoint with your shaving cabinet make sure you consult with your electrician before installing.

1. POSITION CABINET & LEVEL

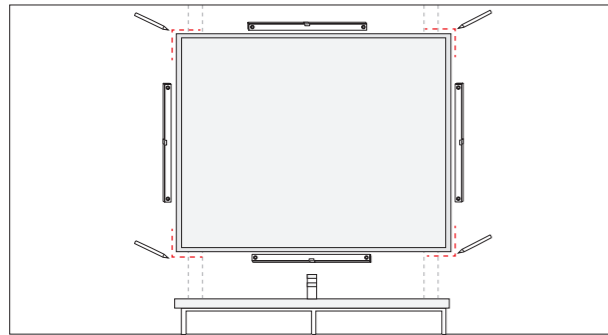

- Place cabinet on flat surface to remove any doors. Remove doors and place flat on soft surface with mirrors facing up to avoid damages.
- Locate support beams and position unit in desired location and check all sides are sitting level.
- Mark the position of the cabinet on all four corners of cabinet

Note: Damage during installation is not covered under ADP warranty.

3. SEALING

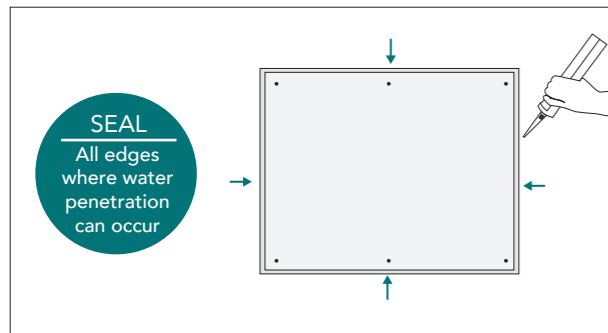

Apply non-acidic silicone to all edges where cabinet meets the wall.

Note: Gap sealant can be used in place of silicone where the unit meets tiled surfaces.

2. SECURING THE CABINET

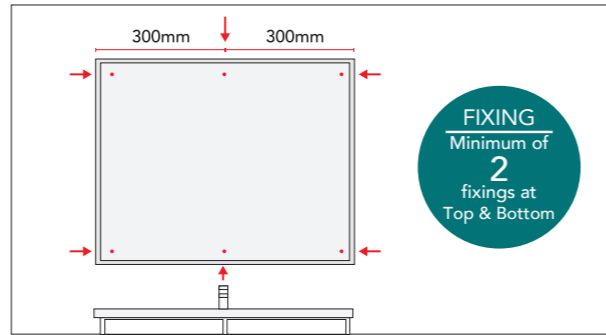

Securely fasten cabinet to the wall through back with appropriate screws/bolts at TOP and BOTTOM of cabinet. Evenly space apart the horizontal fixings at a maximum of 300mm apart.

Note: Where a stud or support beam cannot be located, use an appropriately sized hollow wall anchor.

4. ADJUST DOORS

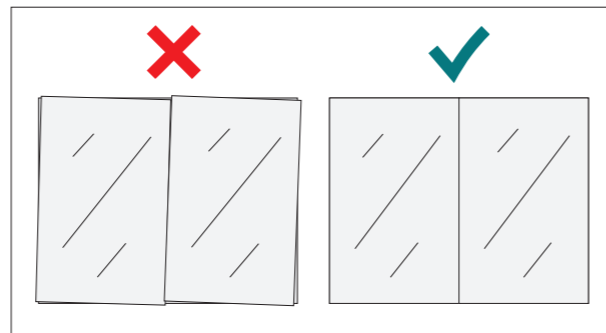

Install doors back onto cabinet and make adjustments to align the doors correctly. See opposite page for instructions.

IT IS THE RESPONSIBILITY OF THE INSTALLER TO MAKE ANY ADJUSTMENTS TO DOORS AFTER INSTALLATION.

OPTION: WHEN RECESSING A MIRRORED SHAVING CABINET

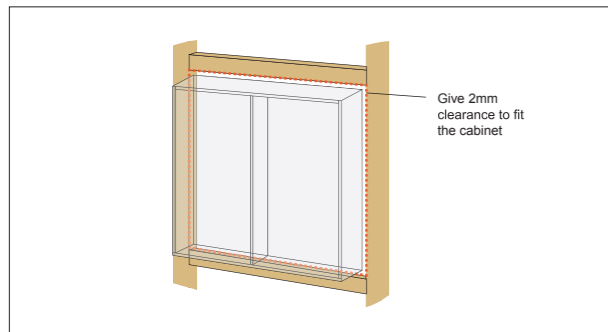

Complete Step 1, cut a hole 4mm bigger than the overall cabinet carcass in the wall. Position and secure cabinet in cut out, go to Step 2.

Note: Make sure the hole has sufficient noggings to fix top and bottom of carcass.

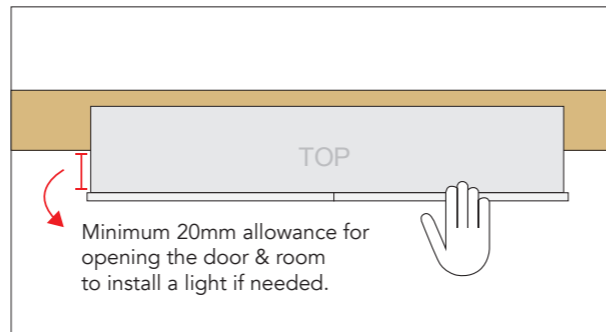

Ensure the cabinet carcass protrudes by a minimum of 20mm from the wall (including tiles) to allow for finger pull on the door.

DOOR HINGE ALIGNMENT & INSTALLATION

SIDE ADJUSTMENT

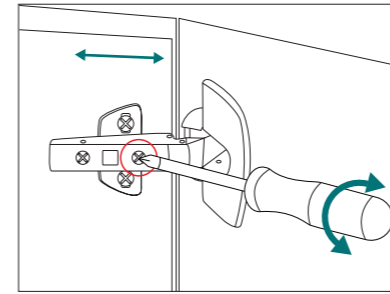

Use front screw to move door to the left or right, or to level each door.

DEPTH ADJUSTMENT

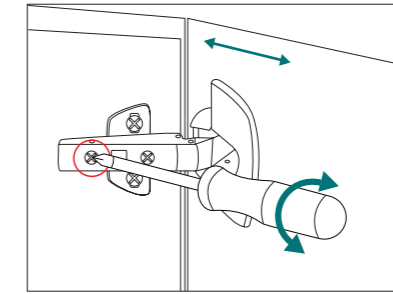

Use back screw to move door inward or outward from carcass.

HEIGHT ADJUSTMENT

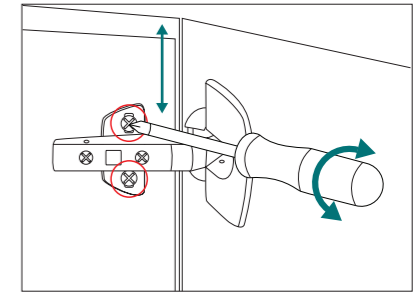

Loosen the top and bottom screw on mount plate, adjust door height by moving door up or down, then retighten screws.

REMOVING & INSTALLING DOORS

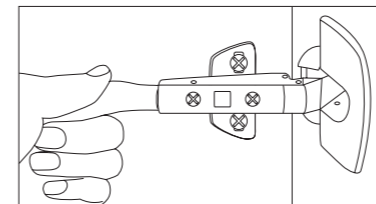

TO REMOVE DOORS:

Apply finger pressure to clip at back of hinge and pull forward to release.

TO INSTALL DOORS:

Align door hinge with hinge mount on carcass, press back of hinge into place and listen for a 'click' to lock the hinge in place. You may need to apply a little force to lock the hinge in place.

REMOVING HINGE FROM DOOR

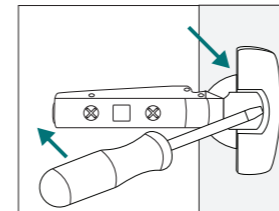

Once you have removed door from the cabinet, using a flat head screw driver, lift and release the top cover plate.

Pull hinge up and out from door. You may need to wiggle the hinge to loosen and use a little force.

REPLACING HINGE ON DOOR

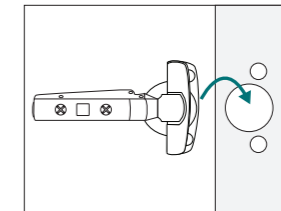

With top cover plate lifted, place hinge into position on door and insert into holes until flush.

Once secured in position, click cover plate down to lock into place.



CARE & MAINTENANCE

CABINETS

- To maintain the finish on your cabinet use only a soft cloth and weak solution of non abrasive detergent.
- To remove scratches, marks, etc. on two pack polyurethane, rub gently with car cutting compound, car polish or household brass/silver cleaner.
- Goods used in construction are water/moisture-resistant, but not water-proof.
- All cabinets should be installed at least 300mm away from showers or bathtubs to avoid water damage.

MIRRORS

FOR BEST RESULTS - use a slightly moistened microfibre cloth to remove dry dirt or grime, then buff clean with dry microfibre cloth or use a soft dry cloth with a tight weave (which is more soft and non-abrasive). This will leave you with a clean, smear-free finish. By using alkaline (ammonia) or acid (vinegar) based products you not only risk damaging the silvered backing of the mirror, but also tend to leave behind streaks and smears.

DO NOT use ammonia-based cleaning products such as glass cleaner. These may erode the mirror's silver backing. Be sure to read the label of any such cleaning products before use.

PROTECTION AGAINST 'BLACK-SPOTTING' - Alkaline, acid and moisture elements can cause the silvered backing of a mirror to darken, this is usually referred to as 'black-spotting'. An easy way to protect your mirror against black-spotting is to regularly oil any exposed edges (i.e. polished or bevelled edges), using non-petroleum based oils (eg. sewing machine oil). This will act as a seal to protect against such elements. Always remember to keep your mirror dry and wipe off any water, moisture or steam.



WARRANTY

NOTE: Unless otherwise stated warranties for ADP products are as follows:

PRODUCT	DOMESTIC WARRANTY	COMMERCIAL WARRANTY
Shaving Cabinets (excluding mirror)	10 years	1 year
Mirrors (including mirrored surfaces on cabinets)	1 year	1 year

Our products come with guarantees that cannot be excluded under the Australian Consumer Law. You are entitled to a replacement or refund for a major failure upon inspection by an authorised representative where a product is found to be defective in construction, material or assembly. You are also entitled to have the goods repaired or replaced if the goods fail to be of acceptable quality and the failure does not amount to a major failure, free of charge.

CONDITIONS

1. Items must be installed by a licensed tradesperson.
2. Failure is due to a fault in the manufacture of the product.
3. Proof of purchase is provided.
4. The installation of the product is in accordance with the instructions provided.

EXCLUSIONS

To the fullest extent permitted by law, the manufacturer excludes all liability for damage or injury to any person, damage to any property and any indirect consequential or other loss or damage. Manufacturer will not be liable for the cost of installation or removal of any unit and the warranty will be VOIDED if damage occurred during or after INSTALLATION or a damaged or incorrect unit has been installed. Door and drawer adjustment; Unsuitable or improper use; Incorrect installation or installation not in accordance with the instructions provided; Installation or part installation by the purchaser or any person other than a LICENSED tradesperson; Normal wear and tear; Inadequate or complete lack of maintenance; water damage; chemical, electrochemical or electrical influences; excessive heat damage or Harsh detergents or abrasive cleaners used on product finishes, are NOT considered a warranty issue.

CLAIM PROCEDURE

For all warranty queries customers are to contact the branch where the product was purchased. These details can be found on your purchase invoice.

SERVICE CALL OUT FEES & CHARGES

In the event of a call out for issues covered under the ADP manufacturer warranty, no call out fees will apply.

If ADP is called out and the cause of the issue falls within the warranty exclusions or the installation instructions have not been adhered to, the following charges will apply:

Call out fee: \$198.00 initial cost, first 15 minutes included.

Service time onsite: \$24.75 / billed in 15 minute increments.

Call out times: Business hours 9am - 5pm.

Note: Response time will depend on technician availability.



WARRANTY AGREEMENT - HOME OWNER TO KEEP

IMPORTANT: Warranty form to be completed by a licensed qualified tradesperson responsible for the installation of this unit. Any warranty will be VOIDED if unit is not installed by a licensed qualified tradesperson.

Cabinet Installed by: _____ Phone: _____

Trade & license number: _____ Date: ____|____|____

Product name/description: _____ Purchase Date: ____|____|____

Product Warranty Number (found on door or drawer inside unit):



Architectural Designer Products Pty Ltd.
P.O. Box 1455, Unanderra NSW 2526 | ABN 34 073 064 721



info@adpaustralia.com.au



www.adpaustralia.com.au



(02) 4271 2444



@adpaustralia